

Developer: Mike Duncan - Allenbach Acres - Portland, Oregon



Preservation of lot values

Sound-abatement solutions

"The masonry structure definitely has esthetically enhanced our project. It also has the benefits of being low maintenance and an effective barrier against sound transmission."

— James Dobrick, Vice President, Mercer Construction Services, Inc.



A sense of 'place' and community identity

Developer: Centex - Bethany Crest - Portland, Oregon

Branch Locations

PUGET SOUND AREA LOCATIONS

AUBURN, WA
1357 W Valley Hwy N 98002
253 939 7854

BELLEVUE, WA
605 119th Ave NE 98005
PO Box 2009, Bellevue 98009
425 452 2300

BELLINGHAM, WA
4140 Bakerview Spur 98226
360 676 2880

EVERETT, WA
9929 Evergreen Way 98204
425 353 9677

MT. VERNON, WA
1912 S Burlington Blvd
98233
360 707 5209

OLYMPIA, WA
3150 29th SW 98512
(Tumwater)
360 357 3343

PORT ORCHARD, WA
1515 Vivian Court 98366
360 876 1845

REDMOND, WA
7760 185th Ave NE 98052
425 881 6700

TECHNICAL SUPPORT:

For questions or additional technical information regarding architectural face brick, contact a Commercial Sales Representative at one of these Mutual Materials locations.

Puget Sound Area:
425 452 2300

Oregon:
503 624 8860

Eastern Washington, Idaho, Montana:
509 924 6699

Western Canada:
604 522 8200

Other U.S. States & Eastern Canada:
503 624 8860 / 800 477 7137

TACOMA, WA
2201 112th St S 98444
253 589 6434

WESTERN OREGON AREA LOCATIONS

CLACKAMAS, OR
15791 SE Piazza Ave 97015
503 655 7167

DURHAM, OR
18230 SW Boones Ferry Rd 97224
PO Box 333, Tualatin 97062
503 624 8850

HILLSBORO, OR
1561 SE Enterprise Circle 97123
503 640 4731

SALEM, OR
2245 Judson St SE 97302
503 375 6050

VANCOUVER, WA
2705 NE 65th Ave 98661
360 693 4766

EASTERN WASHINGTON AREA LOCATIONS

SPOKANE, WA
6721 E Trent Ave 99212
509 922 4100

WESTERN CANADA AREA LOCATION

NEW WESTMINSTER, BC
607 Agnes Street V3M 1G9
604 522 8200

To find our products at distributors or home improvement centers in your area, please visit our website.



www.mutualmaterials.com

Brick Fences & Entries

"When potential customers see our brick fence, they know this is a quality project."

— Roger Shubert, President, Mercer Construction Services, Inc.



Potential for greater density

A feeling of security for your customer

Developer: Mercer Construction Services - Chelsea Place - Redmond, Washington

Home buyers of the nineties demand quality, security and value in their homes and neighborhoods. Masonry offers all this and more.



Marylhurst - Lake Oswego, Oregon

Excellent marketing opportunities

Higher project visibility

Improved lot value



Above and Cover Photo: The Highlands - Tigard, Oregon

Developers who routinely use masonry fences and entries enjoy the benefits of shorter market time, higher margins, and that image of quality.



An identity and 'signature' for the development

Developer: Carl Coffman - Orchard Lake - Clackamas, Oregon

Mutual Materials has developed a system which is the most cost-effective method for building masonry fences.

These fences can be designed as 4-inch, single-wythe (single brick or block) walls which span between columns, eliminating the need for expensive concrete footings and reinforcing. These designs also reduce excavation costs.

The flexibility of this design allows the developer to tailor a masonry fence which best suits the project site.

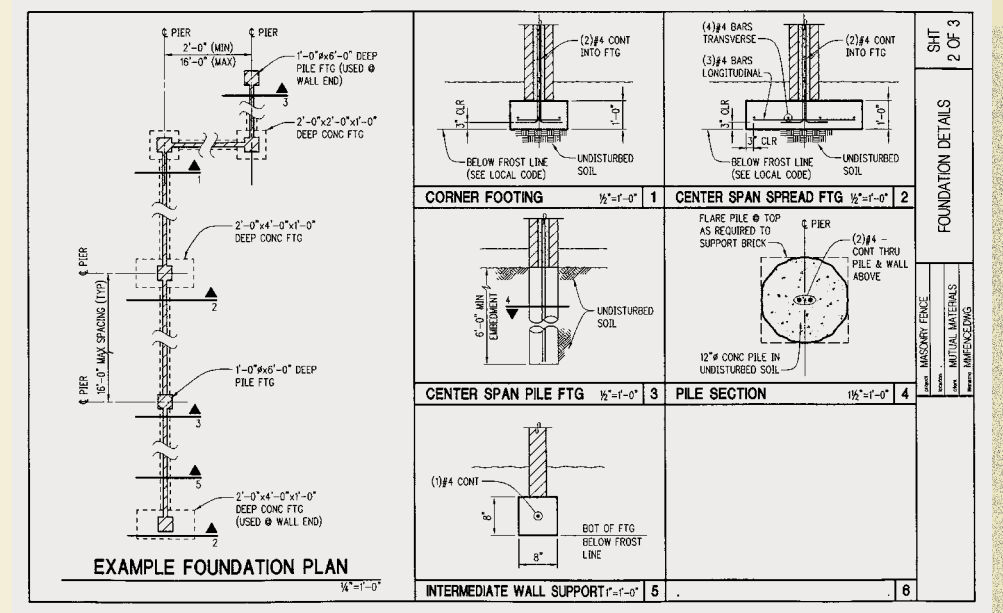

Many design options are available.

For more information regarding masonry fences and entries consult your Mutual Materials Representative.

